

Eclipse Winnox Burners

Model WX0600

Version 1

Parameter		Specifications	
Blower Type		Packaged Blower	Remote Blower
Maximum Input, BTU/hr (kW) <i>NOTE: Capacities given without air filter. Contact factory for chamber pressures outside the given range, or varying chamber pressure conditions.</i>	Chamber Pressure "w.c. (mbar)	Nominal (50Hz and 60Hz)	Pressure at Air Inlet 1 psig (70 mbar)
	-5.0 (-12.5)	6,690,000 (1960)	8,280,000 (2420)
	-3.0 (-7.5)	6,430,000 (1880)	7,920,000 (2320)
	0.0	6,000,000 (1760)	7,340,000 (2150)
	1.0 (2.5)	5,870,000 (1720)	7,140,000 (2090)
	2.0 (5.0)	5,720,000 (1680)	6,930,000 (2030)
Minimum Input, BTU/hr (kW)		400,000 (120)	400,000 (120)
Fuel Inlet Pressure at Ratio Regulator, "w.c. (mbar)¹	Maximum	2.2 (152)	2.7 (186)
	Minimum	1.2 (83)	1.7 (117)
Maximum Chamber Temperature, °F (°C) <i>NOTE: Tube and plug temperatures should be reduced 150°F when using propane or butane.</i>		Standard combustion tube: 1300 (704) High temperature combustion tube: 1550 (843) Refractory plug: 1800 (982)	
Flame Length	Alloy Tube	Flame is inside tube at all times	
Excess Air, % at High Fire		50%	
Piping		NPT or BSP burner piping available	
Flame Detection		Flame rod or UV scanner	
Fuels		Natural gas, propane, butane ² <i>For any other mixed gas, contact Eclipse Inc.</i>	
Weight, lbs (kg)	Alloy Tube	505 (228)	335 (152)
	Refractory Plug	456 (207)	289 (131)
Approvals			

¹ For proper performance, this pressure must be kept constant across the burner operating range.

² See Design Guide for more information about typical fuel composition and properties.

- All information is based on laboratory testing. Different chamber size and conditions will affect data.
- Maximum inputs for packaged blower versions are given for the standard combustion air blower without an inlet air filter.
- All inputs are based on gross calorific values and standard conditions: one atmosphere, 70°F (20°C).
- Eclipse reserves the right to change the construction and/or configurations of our products at any time without being obliged to adjust earlier supplies accordingly.

Performance Graphs

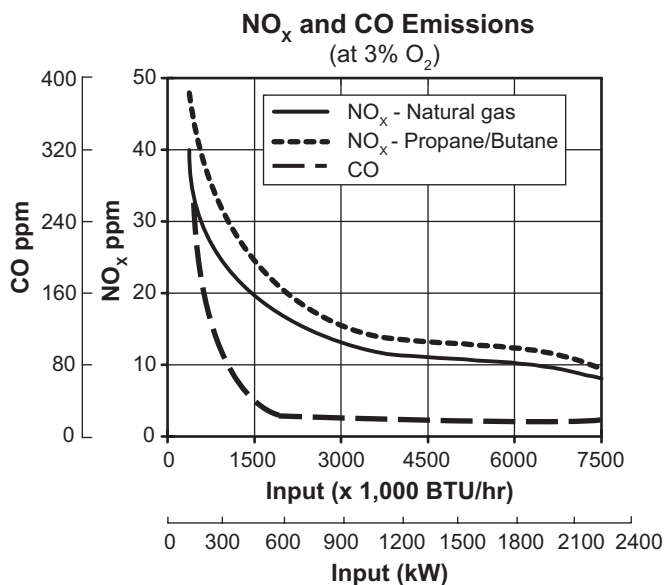
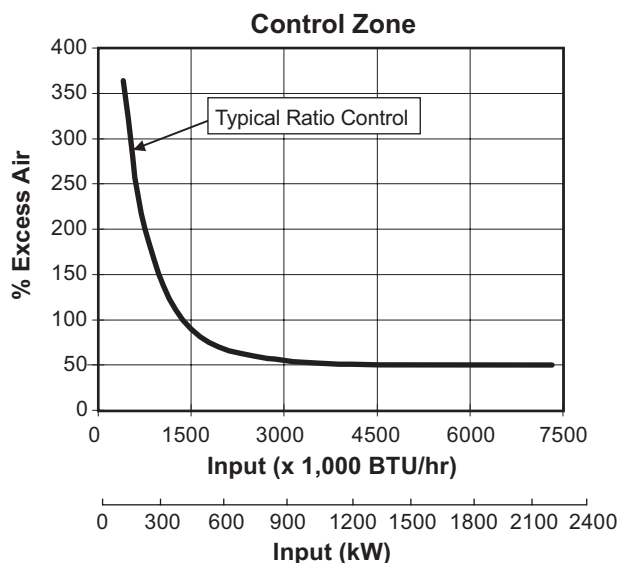

NOTE: Input at low fire changes with ratio regulator adjustment.

Secondary By-Pass Fuel Setting:

Fuel	ΔP "w.c. (mbar)*
Natural Gas	8.0 (20.0)
Propane	8.0 (20.0)
Butane	8.0 (20.0)

*Measured between Tap "E" and the chamber @ low fire.

Fuel/Input Measurement

System design must include fuel flow measurement upstream of the burner. Recommended is the Eclipse 8-5 FOM (Fuel Orifice Meter) assembly number 302087-5 for natural gas. See Bulletin 930 for details.

NOTE: Insure burner inlet pressures are met.

NO_x and CO emission data is given for:

- Ambient combustion air (~70°F, 20°C)
- Less than 1000°F (540°C) firing chamber
- Minimal process air velocity
- Low fire input adjusted to 550,000 BTU/hr (161 kW)
- Neutral chamber pressure

Emissions are influenced by:

- Chamber conditions
- Fuel type
- Firing rate
- Ratio regulator adjustments
- Combustion air temperature

CO emission is largely influenced by chamber conditions. Contact your local Eclipse representative for an estimate of CO emission on your application.

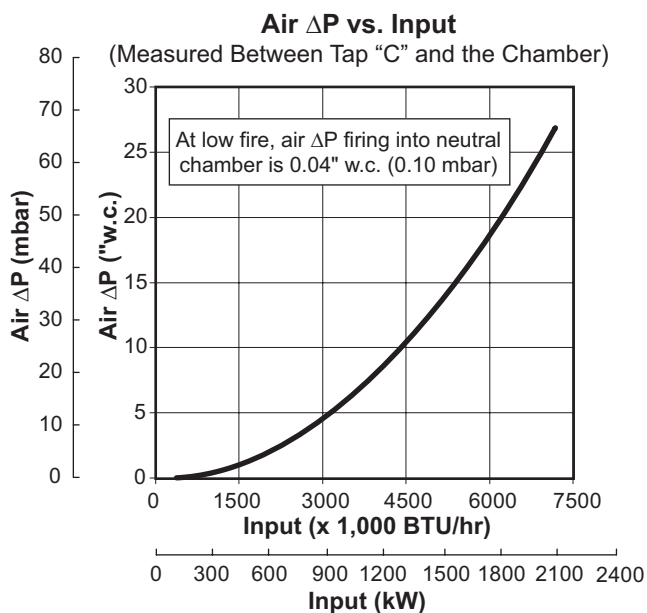

Packaged Blower Dimensions

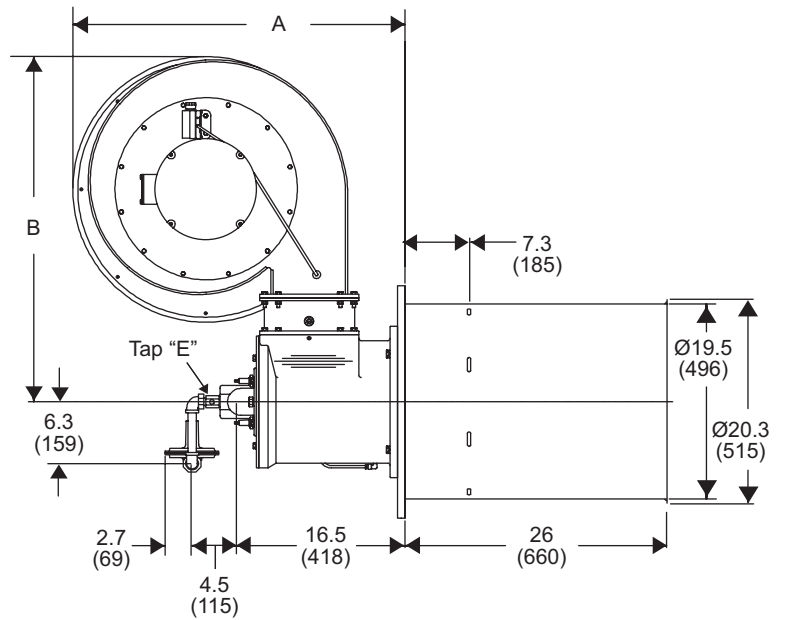
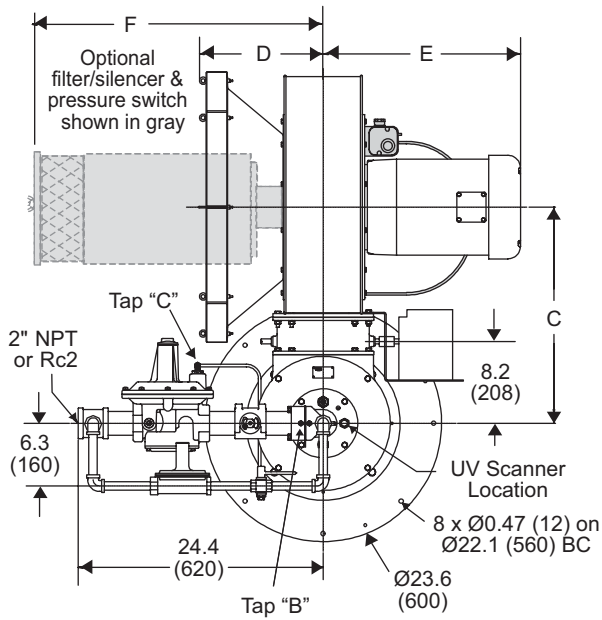

Blower Type		
	60 Hz	50 Hz
Dimensions inch (mm)		
A	33.00 (838)	34.05 (865)
B	35.08 (891)	37.52 (953)
C	21.61 (549)	23.19 (589)
D	12.36 (314)	12.36 (314)
E	19.69 (500)	20.00 (508)
F	37.52 (953)	37.52 (953)

Refractory Plug

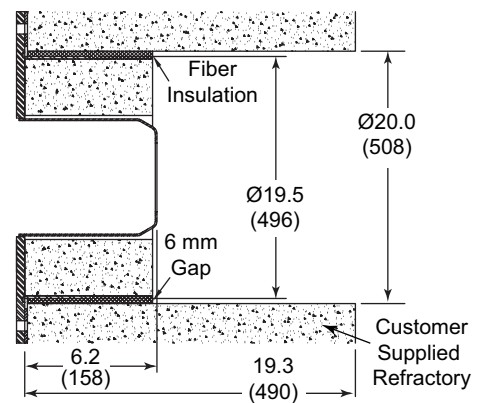

Remote Blower

NOTE: For Remote Blower applications, consult factory.

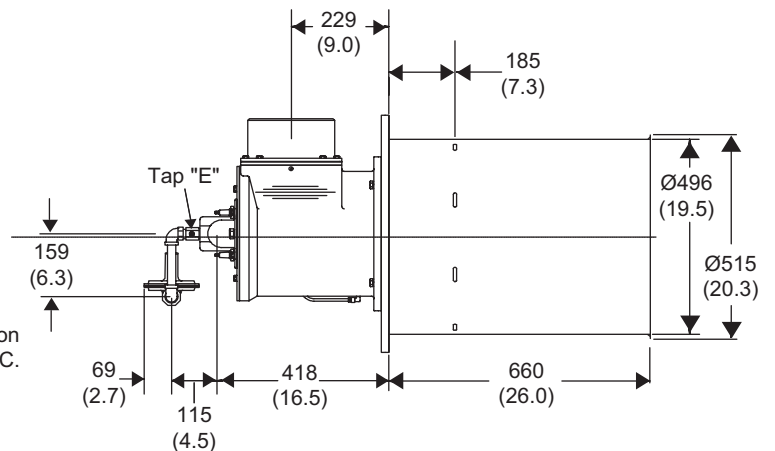
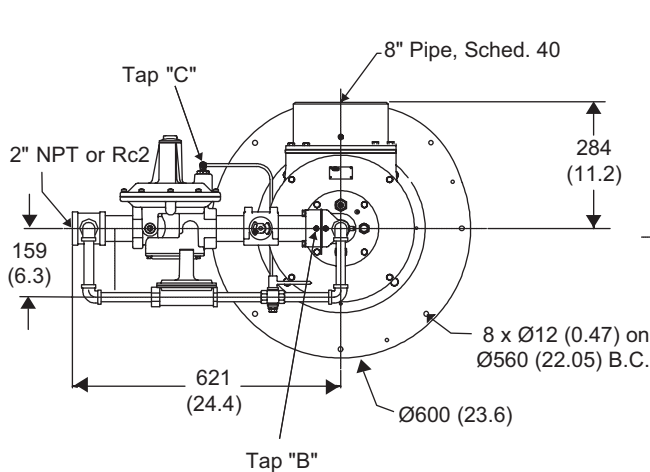



Offered By:

Power Equipment Company
2011 Williamsburg Road
Richmond, Virginia 23231
Phone (804) 236-3800
Fax (804) 236-3882

www.peconet.com